

Z4.270

Specifications

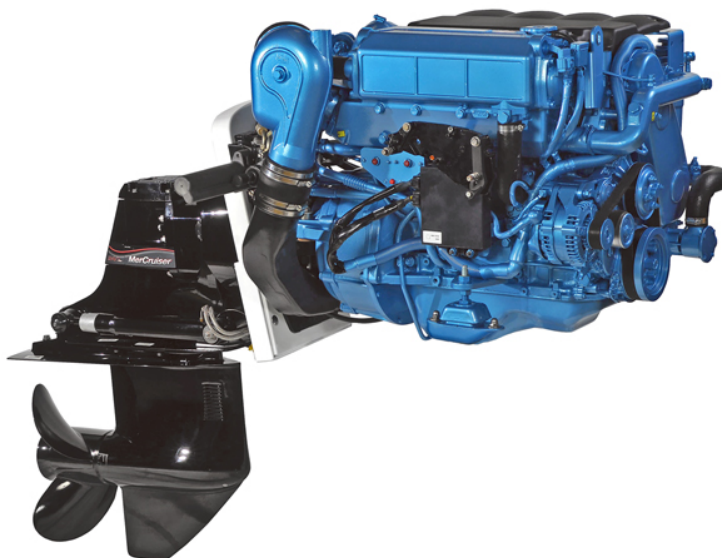

Power at crankshaft	194.9 kW [265 hp]	Engine base	Toyota
Displacement	2.982 l [182 in ³]	Fuel system	Direct injection High pressure Common Rail Electronically controlled
Configuration	4 cylinders in line	Air intake	Turbocharged with intercooler
Operation type	4 stroke Diesel	Cooling	Closed cooling with heat exchanger
Bore & Stroke	96 x 103 mm [3.78 x 4.06 in]	Max mounting angle	7° Front up 7° Front down
Compression ratio	15:1	Alternator	12 Volt 100 Amp
Rated speed	3600 rpm	Rating	M6
Idling speed	700 rpm	Emission compliance	IMO Annex VI compliant RCD 94/25/EC EPA marine Tier 3 BSO 2
Peak torque	668.5 Nm		
Peak torque speed	2000 rpm		
Dry weight with Bravo X Two	472 kg [1040 lbs]		

Z4.270

194.9 kW [265 hp] at 3600 rpm

TECHNICAL DESCRIPTION

Engine block

- 4 cylinders in line
- 4 valves per cylinder
- Dual overhead camshafts (DOHC)
- Watercooled exhaust manifold
- Internal balancers

Fuel system

- Common Rail fuel injection system
- Fuel filter with hand primer
- Integrated fuel cooler

Lubrication system

- Replaceable full-flow oil filter
- Oil dipstick
- Transmission oil cooler

Cooling system

- Closed cooling with heat exchanger
- Gear driven self-priming raw water pump
- Coolant circulating pump
- Water cooled exhaust elbow

Electrical system & Instrumentation

- 12V 100A alternator
- 12V Electrical system
- Complete instrumentation including key switch and alarms
- Extension cable harness with plug-in connection

Air intake

- Dry turbocharger
- Intercooler

Other features

- Flexible engine mounting
- Transom (Trim system, Bull Horn and Mercathode)
- Trim indicator

Optional equipment & accessories

- Throttle and shift controls
- Additional instrumentation, Flying bridge extension harness
- Water boiler systems
- Complete fuel systems
- Complete exhaust systems

RATING

- Up to 500 annual operating hours
- Load factor up to 35%
- Full power for no more than 30 minutes out of each 8 hours of operation. The remaining operation time must be at or below cruising speed

TRANSMISSIONS

Stern Drive

- Bravo X One
- Bravo X Three
- Bravo X Two

Contact your local dealer for more details and availability for transmission model and type.

PERFORMANCE CURVES

Power at crankshaft

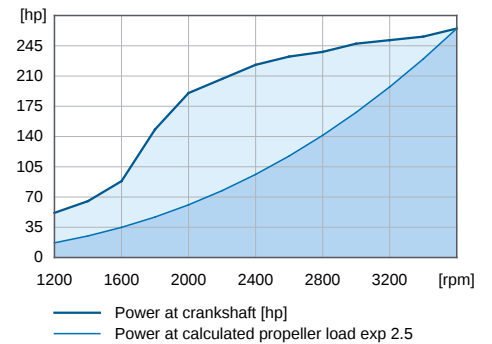

Torque at crankshaft

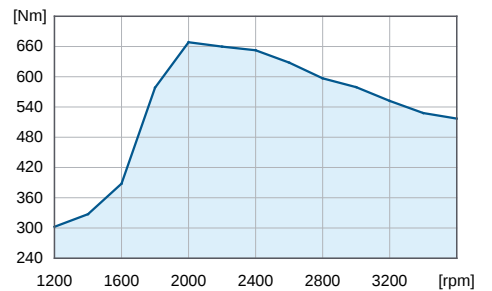

Fuel consumption

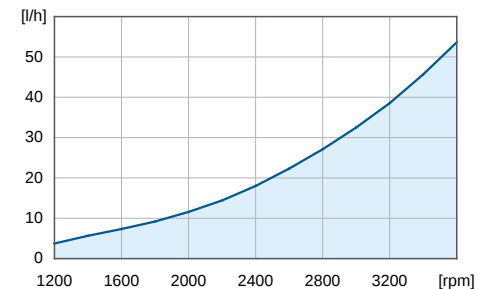

DIMENSIONS WITH BRAVO X TWO

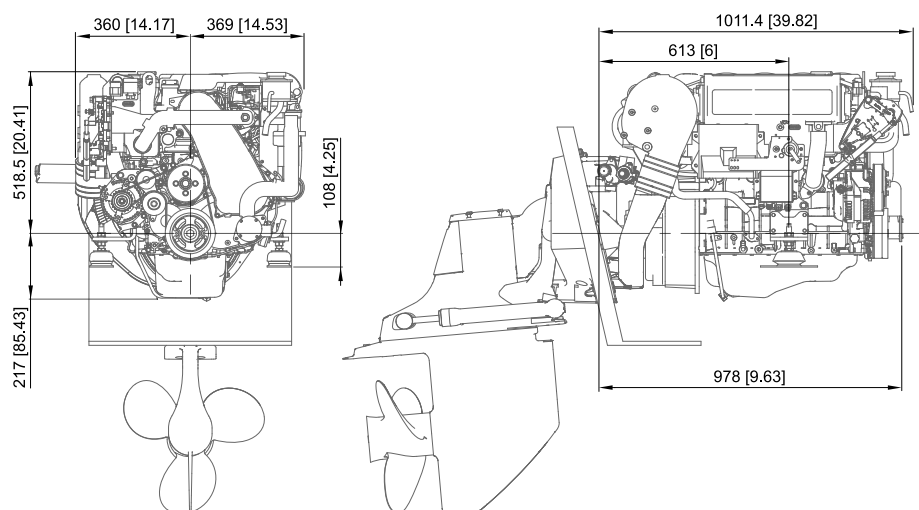

Nanni Industries S.A.S. France

11, Avenue Mariotte - Zone Industrielle
33260 La Teste - France
Tel: +33 (0)5 56 22 30 60
Fax: +33 (0)5 56 22 30 79

Pabulum d.o.o.

Dražanac 4 - 21000 Split
Tel/fax: +385/21/46 38 16
www.pabulum.hr
e-mail: info@pabulum.hr

Technical data according to ISO 8665. Specifications are subject to change without notice. Images and illustrations may show non standard equipments. All combination of equipment & accessory are not available.

20160303-A ENG