

Walker Engineering  
Air Filter and Coalescer Service  
Information for CCE AirSep  
Equipped Engines



Walker Engineering Enterprises, Inc.  
9255 San Fernando Road  
Sun Valley, CA 91352

Contact: Ken Sacks, Sales and Technical  
Phone (818) 252-7788 x-316  
Fax (818) 252-7785  
Email to: [kens@walkerairsep.com](mailto:kens@walkerairsep.com)

# CCE SERVICE PROCEDURE

**STEP 1** Remove v-band Clamp and airfilter.

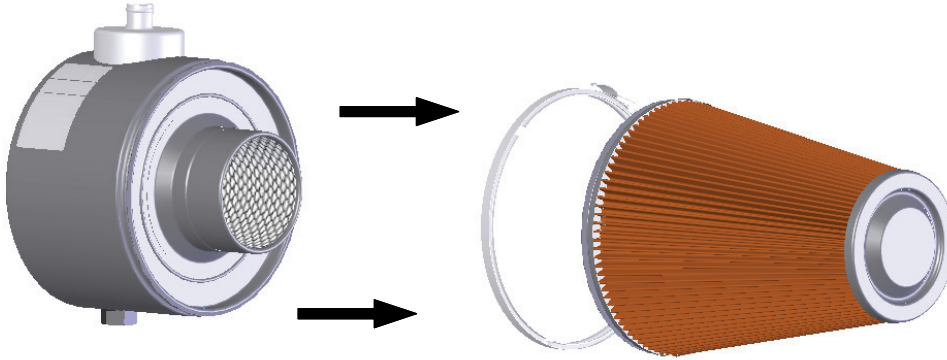

**STEP 2** Carefully remove silencer lid and o-rings.

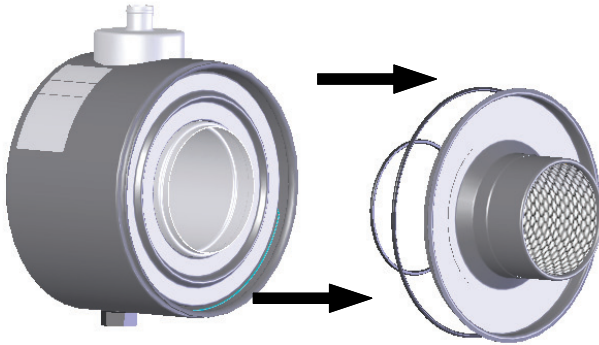

**STEP 3** Carefully raise service handle on primary element. Pull out of housing with equal force.

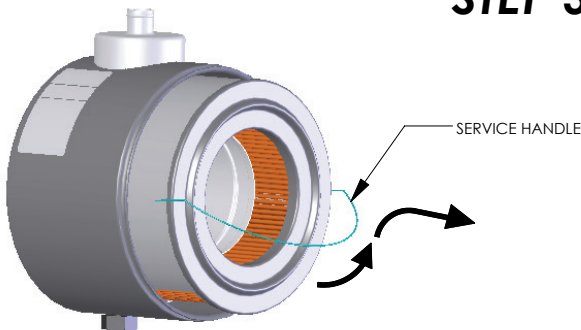

**STEP 4** Once primary element is removed, reach inside housing and pull first stage element down. (Discard both elements and replace with new). Reassemble by placing o-rings, silencer lid, v-band and air filter back into place.

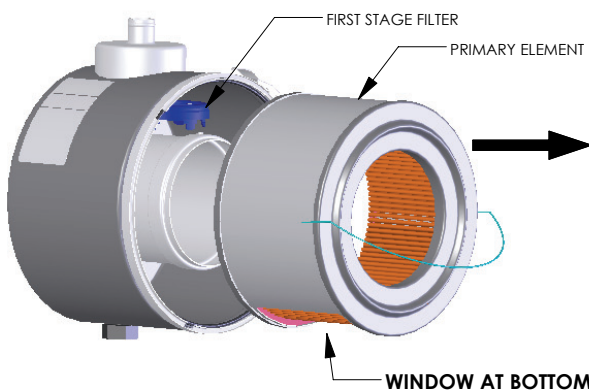

**IMPORTANT:** Drainage window MUST be positioned at bottom of primary element or system will malfunction. BOTH first stage and coalescing elements MUST be replaced at the same time.



# AIR FILTER CLEANING INSTRUCTIONS



**1) PRE-CLEANING**  
Remove air filter from AIRSEP. Tap filter element to dislodge any large dirt particles. Gently brush with a soft bristle brush.



**2) SPRAY ON CLEANER**  
Spray liberal amount of cleaning solution onto entire filter element and allow to soak for 10 minutes.

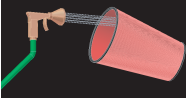

**3) RINSE OFF**  
Rinse off the element with low pressure water. Always flush from the clean side to dirty side. This removes the dirt and does not drive it into the filter.



**4) DRYING THE FILTER**  
Always dry naturally. After rinsing, shake off all excess water and allow the element to air dry naturally or in the sun.



**5) RE-OILING THE FILTER**  
After cleaning air filter always re-oil before using. Apply oil down each pleat. Wait ten minutes and re-oil any light visible spots

**6) CLEAN VACUUM REGULATOR/LIMITER**  
Using a slot head screwdriver, loosen clamp and remove filter. Then follow steps 1 through 5. To clean the Vacuum Limiter do not attempt to remove the filter. Remove the entire vacuum limiter and follow steps 1 through 5.

**7) AIR FILTER INSTALLATION**  
Reinstall air filter on AIRSEP. Use Walker Air Filter Sealing Compound (CD955) when reinstalling air filter. Be sure to inspect springs and replace if worn.

## FAQ's and Air Filter Cleaning Tips

This kit cleans and oils up to four (4) 9x12 or equivalent sized filters.

How often do I need to clean my air filter? You should clean your air filter every 250 to 300 hours, or every year whichever comes first.

How often should I replace my air filter? Replace your air filter after four (4) cleanings or every 3 or 4 years depending on condition of filter.

Is it better for my engine if I clean the air filter more often? No, follow the cleaning interval listed above. Cleaning too often will impair the vacuum action of the AIRSEP.

Can I use other liquids to clean and oil my air filter? No, your AIRSEP air filter may be damaged by harsh detergents or liquids other than the recommended cleaner in this kit. Other oils may be too light or too heavy to properly capture airborne dirt. Use the appropriate Walker kit to clean and recondition your standard or blue air filters.

### CAUTION NEVER CLEAN USING:

- Gasoline
- Part Cleaner Solvents
- Caustic Cleaning Solutions
- Strong Detergents
- High Pressure Water
- High Pressure Air
- Steam Cleaners

### NEVER OIL FILTER:

- Using Transmission Fluid
- Using Motor Oil
- Using Diesel Fuel
- Using WD-40
- Using Other Oils

# Air Filter Cleaning Kit Guide

Standard Air Filter Cleaning  
and Re-oiling Kit  
(For Standard **RED** Air Filters)

Blue Air Filter Cleaning  
and Re-oiling Kit  
(For **BLUE** Air Filters)

**DDF9000**

**BAF2000**



Each Kit Contains:

(1) 32 OZ Bottle of Cleaner with pump spray applicator and (1) 12 OZ Bottle of Oil.

Look for the **RED** and **BLUE** colored dots on the boxes to easily identify the kit you need.

**Air Filter Cleaning Kit with Spray on Air Filter Oil!**

(For Standard **RED** Air Filters)

Part Number; AAF 1000

### Fleet Size Bulk Products

MD301, 1 Gallon **RED** Air Filter Oil

MD306, 6 Gallon Air Filter Cleaner

CD962, 1 Gallon **BLUE** Air Filter Oil